

NEW FORD E-TRANSIT CHASSIS CAB

- Pre-Collision Assist – Υποβοήθηση έναντι σύγκρουσης με έκτακτη υποβοήθηση πέδησης (Emergency Brake Assist), ενεργό σύστημα πέδησης (Active Braking) και ανίχνευση πεζών με προειδοποίηση προσέγγισης (Forward Alert)
- Υποβοήθηση διατήρησης λωρίδας (με προειδοποίηση Lane-Keeping Alert και υποβοήθηση Lane Keeping Aid)
- Cruise control – Σύστημα σταθερής ταχύτητας με ρυθμιζόμενο σύστημα περιορισμού της ταχύτητας
- Σύστημα περιορισμού ταχύτητας (κόφτης) - 120 km/h
- Αυτόματο σύστημα κλιματισμού
- Ραδιόφωνο FM/DAB με έγχρωμη οθόνη αφής 12" Ford SYNC 4, συμβατότητα MP3, και υποδοχές USB για τη σύνδεση εξωτερικών συσκευών, GPS και modem FordPass Connect
- Σύστημα πλοήγησης (Navigation System)
- Ηλεκτρικά ρυθμιζόμενοι και θερμαινόμενοι εξωτερικοί καθρέφτες με εσωματωμένα φλας
- Περιστροφικός επιλογέας ταχυτήτων
- Τέσσερις επιλογές τρόπου οδήγησης (Normal, Eco, Slippery and Low)
- Ηλεκτρικό χειρόφρενο
- Κουμπί διακοπής/εκκίνησης του οχήματος χωρίς κλειδί
- Κεντρικό κλειδωμα με τηλεχειρισμό
- Αντικλεπτικό σύστημα με immobiliser
- Αερόσακκος οδηγού
- Anti-lock braking system (ABS) – Σύστημα αντιπλοκαρίσματος των φρένων με ηλεκτρονική κατανομή πέδησης (EBD)
- Emergency Brake Assist (EBA) – Υποβοήθηση των φρένων στο απότομο φρενάρισμα
- Electronic Stability Control (ESC) – Ηλεκτρονικό σύστημα ευστάθειας
- Hill Start Assist (HSA) – Υποβοήθηση εκκίνησης στην ανηφόρα
- Roll Stability Control (RSC) – Σύστημα αποτροπής ανατροπής
- Χαλύβδινες ζάντες 16"
- Γρίλια 3 ράβδων με ανοδιωμένες μπλε μπάρες
- Προβολείς αλογόνου εστιασμένης δέσμης με στατικούς λαμπτήρες στροφής
- Φώτα ημέρας
- Ηλεκτρικά ανοιγόμενα παράθυρα
- Προβολείς ομίχλης
- Αυτόματα φώτα
- Αυτόματοι υαλοκαθαριστήρες
- Θερμαινόμενο παρμπρίζ Quickclear®
- Κάθισμα οδηγού με 4 ρυθμίσεις και υποβραχιόνιο
- Διθέσιο κάθισμα συνοδηγού (με αποθηκευτικό χώρο από κάτω) με αναδιπλούμενο τραπέζι
- Θερμαινόμενα καθίσματα οδηγού και συνοδηγού
- Ηλεκτρικό υποβοηθούμενο τιμόνι
- Ρυθμιζόμενη κλίση και ύψος κολώνας τιμονιού
- Sensico Δερμάτινο τιμόνι
- Τριφασικό καλώδιο φόρτισης «Mode 3» 32amp

ΤΙΜΕΣ	Single Chassis Cab	Single Cab Pick-Up
350L L3 RWD 135kW (184PS) 68kWH Electric Drive	€ 56,900	€ 58,900
420L L3 RWD 200kW (272PS) 68kWH Electric Drive	€ 60,500	€ 62,500
350EF L4 RWD 135kW (184PS) 68kWH Electric Drive	€ 57,900	€ 60,300
420EF L4 RWD 200kW (272PS) 68kWH Electric Drive	€ 61,500	€ 63,900
Additional for Metallic Paint	€ 600	

**5 Χρόνια εργοστασιακή εγγύηση & 12 Χρόνια αντισκουριακή εγγύηση
8 χρόνια εγγύηση μπαταρίας**

- Οι πιο πάνω τιμές συμπεριλαμβάνουν φόρο κατανάλωσης, Φ.Π.Α 19%, τέλη εγγραφής & άδεια κυκλοφορίας
- Οι τιμές και ο εξοπλισμός μπορεί να αλλάξουν χωρίς καμία προειδοποίηση

E-TRANSIT SINGLE CHASSIS CAB – 350 GVM*

	L3 H1	L4 H1
DIMENSIONS (MM)		
A Overall length	6022	6579
B Overall width with mirrors (standard/wide)	2474/2746	2474/2746
Overall width with folded back mirrors (standard/wide)	2112/2119	2112/2119
Overall width without mirrors (SRW)	2052	2052
C Overall height (maximum)	2214	2215
D Front of vehicle to front wheel centre	1023	1023
E Wheelbase	3954	3954
N Chassis frame length	3592	4149
O Floor/chassis frame height*	718-763	722-779
Q Rear of cab to front wheel centre	1407	1407
R Rear of cab to rear wheel centre	2547	2547
FLOAT DIMENSIONS (MM)**		
Overall length (including float)	6204	6797
Overall width (including float) without mirrors (SRW)	2098	2098
Internal loadspace width (SRW)	2038	2038
Internal loadspace length	3645	4235
TURNING CIRCLE (M)		
Kerb to kerb	14.9-15/15.3	14.9-15/15.3
WEIGHTS AND PAYLOAD (KG)		
Max. gross payload (excluding driver)	1341-1341	1324-1324
Max. gross payload with float (excluding driver)	1001-1001	942-942
Min. kerb mass♦ (excluding driver)	2159-2159	2176-2176
Min. kerb mass♦ with float (excluding driver)	2499-2499	2558-2558

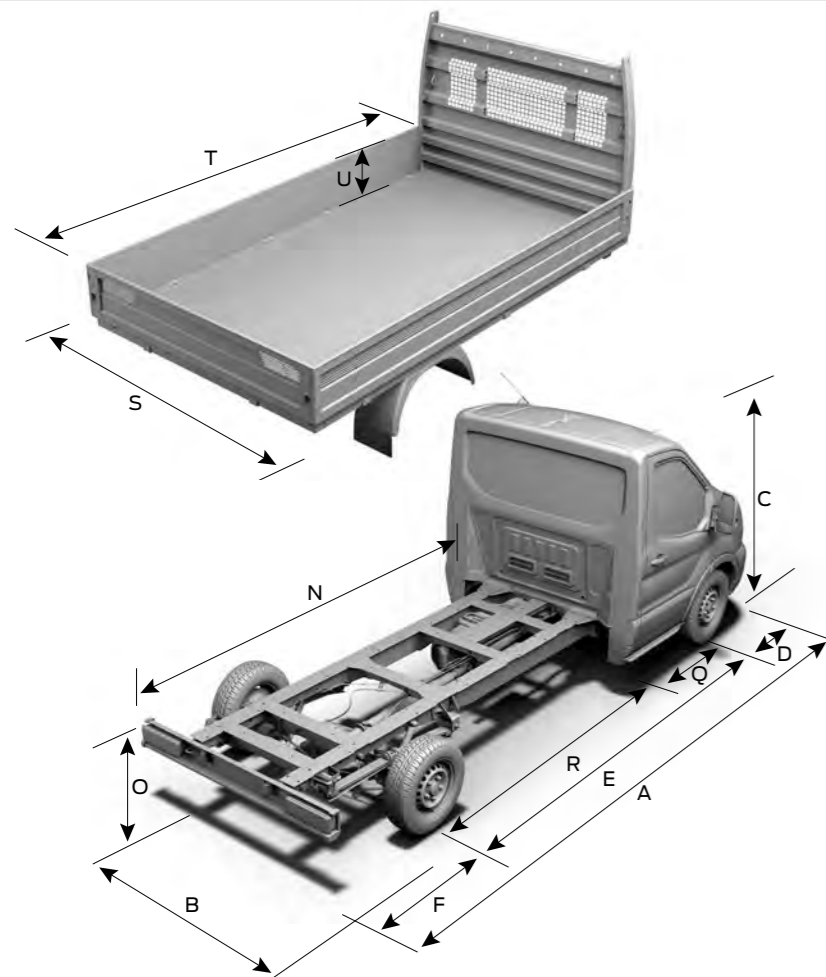

L3 H1



L4 H1

	L3 H1	L4 H1
MOTOR – 68 KWH ELECTRIC DRIVE 135/198 KW (184/269 PS) 1-SPEED AUTOMATIC		
Combined energy consumption kWh per 100 kms ⁰	32.0-32.1	32.0-32.1
Combined energy consumption with float kWh per 100 kms ⁰	34.4	34.6
Torque Nm ⁰⁰	430	430
WLTP Overall Range (kilometers) ⁰⁰⁰	252	252
WLTP Overall Range with Float (kilometers) ⁰⁰⁰	241	240
WLTP Motorway Range (kilometers) ⁰⁰⁰	191	191
WLTP Motorway Range with Float (kilometers) ⁰⁰⁰	183	183
CHARGE OPTIONS 0-100% CHARGE (MAX. HRS)		
230 V outlet with Ford Universal Charge Cable***	49.3	49.3
Ford Connected Wallbox 7.4 kW 1-phase tethered***	11.5	11.5
Ford Connected Wallbox 11.0 kW 3-phase tethered***	8.0	8.0
CHARGE OPTIONS 15-80% CHARGE (MINS)		
High-powered 115 kW DC charging***	34	34

L3 = Long wheelbase, L4 = Long wheelbase extended length. H1 = Low Roof. SRW = Single rear wheels. All dimensions (shown in mm) are subject to manufacturing tolerances and refer to minimum specification models and do not include additional equipment.

*All E-Transit Chassis Cab variants are rear-wheel drive vehicles with Zero Evaporative Emissions.

Height dimensions show the range from minimum to maximum of a fully laden, lowest payload vehicle to unladen highest payload vehicle. These illustrations are for guidance only. **VDA method This is the method used by the Verband der Automobilindustrie (VDA) in Germany. A VDA figure is determined by filling the loadspace with 'litre' blocks, each measuring 200x100x50 mm. The blocks are then counted, and the numerical result is converted into cubic metres.

***Charging performance for E-Transit Single Chassis Cab 350 GVM. Charge power can decrease with increasing state of charge. Actual charge times and charge speeds can vary based on different factors (e.g. weather, temperature, driving behaviour, route profile, vehicle condition, age and condition of the lithium-ion-battery, used charging infrastructure).

⁰The declared fuel/energy consumptions, CO₂-emissions and electric ranges are determined according to the technical requirements and specifications of the European Regulations (EC) 715/2007 and (EU) 2017/1151 as last amended. Light Duty vehicles type-approved using the Worldwide Harmonised Light Vehicle Test Procedure (WLTP) will have fuel/energy consumptions and CO₂-emission information for New European Drive Cycle (NEDC) and WLTP. WLTP will fully replace the NEDC latest by end of the year 2020. The applied standard test procedures enable comparison between different vehicle types and different manufacturers. In addition to the fuel efficiency of a vehicle, driving behaviour as well as other non-technical factors play a role in determining a vehicle's fuel/energy consumption, CO₂ emissions and electric ranges. CO₂ is the main greenhouse gas responsible for global warming.

⁰⁰Calculated via peak performance of the electric motor(s) at peak battery power. Your results may vary.

⁰⁰⁰Based on full charge of E-Transit Single Chassis Cab 350 GVM. Estimated range using Worldwide Harmonised Light Vehicle Test Procedure (WLTP). Figures shown are for comparability purposes and should only be compared with other vehicles tested to the same technical procedures. Actual range varies with conditions such as external elements like temperature, driving behaviours, route profile, vehicle maintenance, and lithium-ion battery age and condition. WLTP Overall Range reflects a combined driving cycle and WLTP Motorway Range reflects motorway driving – both tests are conducted in controlled conditions with an ambient temperature of 23 degrees Celsius and no climate or electrical load.

♦Kerb mass is affected by many factors such as bodystyles, engines and options. It is the weight of a standard-specification base vehicle (different series will have different kerb masses), including fluids and fuel tank 90% full, but without the driver (75 kg), crew or cargo. Payload within this guide is the difference between gross vehicle mass (GVM) and kerb mass with a further 75 kg deduction for the weight of the driver. It must be noted that actual weight will always be subject to manufacturing tolerances which may result in payload variations between this guide and actual weight. For customers intending to load vehicle close to maximum payload, we suggest you also add a margin for error of 5% of kerb mass to the kerb mass figure before calculation, to reduce risk of overloading. **NB:** It is the responsibility of the vehicle operator to ensure their vehicles are legally compliant for road use. For rear float option vehicles, kerb mass is increased and payload reduced.

Note The charging rate decreases as battery reaches full capacity. Your results may vary based on peak charging times and battery state of charge.

E-TRANSIT SINGLE CHASSIS CAB – 425 GVM*

	L3 H1	L4 H1
DIMENSIONS (MM)		
A Overall length	6022	6579
B Overall width with mirrors (standard/wide)	2474/2746	2474/2746
Overall width with folded back mirrors (standard/wide)	2112/2119	2112/2119
Overall width without mirrors (SRW)	2052	2052
C Overall height (maximum)	2214	2215
D Front of vehicle to front wheel centre	1023	1023
E Wheelbase	3954	3954
N Chassis frame length	3592	4149
O Floor/chassis frame height*	718-763	722-779
Q Rear of cab to front wheel centre	1407	1407
R Rear of cab to rear wheel centre	2547	2547
FLOAT DIMENSIONS (MM)**		
Overall length (including float)	6204	6797
Overall width (including float) without mirrors (SRW)	2098	2098
Internal loadspace width (SRW)	2038	2038
Internal loadspace length	3645	4235
TURNING CIRCLE (M)		
Kerb to kerb	14.9-15/15.3	14.9-15/15.3
WEIGHTS AND PAYLOAD (KG)		
Max. gross payload (excluding driver)	2091	2074
Max. gross payload with float (excluding driver)	1751	1692
Min. kerb mass [♦] (excluding driver)	2159	2176
Min. kerb mass [♦] with float (excluding driver)	2499	2558

	L3 H1	L4 H1
MOTOR – 68 KWH ELECTRIC DRIVE 135/198 KW (184/269 PS) 1-SPEED AUTOMATIC		
Combined energy consumption kWh per 100 kms ⁰	32.6	32.7
Combined energy consumption with float kWh per 100 kms ⁰	34.8	35.0
Torque Nm ⁰⁰	430	430
WLTP Overall Range (kilometers) ⁰⁰⁰	250	249
WLTP Overall Range with Float (kilometers) ⁰⁰⁰	239	283
WLTP Motorway Range (kilometers) ⁰⁰⁰	190	190
WLTP Motorway Range with Float (kilometers) ⁰⁰⁰	183	183
CHARGE OPTIONS 0-100% CHARGE (MAX. HRS)		
230 V outlet with Ford Universal Charge Cable***	49.3	49.3
Ford Connected Wallbox 7.4 kW 1-phase tethered***	11.5	11.5
Ford Connected Wallbox 11.0 kW 3-phase tethered***	8.0	8.0
CHARGE OPTIONS 15-80% CHARGE (MINS)		
High-powered 115 kW DC charging***	34	34

L3 = Long wheelbase, L4 = Long wheelbase extended length. H1 = Low Roof. SRW = Single rear wheels. All dimensions (shown in mm) are subject to manufacturing tolerances and refer to minimum specification models and do not include additional equipment.

*All E-Transit Chassis Cab variants are rear-wheel drive vehicles with Zero Evaporative Emissions.

Height dimensions show the range from minimum to maximum of a fully laden, lowest payload vehicle to unladen highest payload vehicle. These illustrations are for guidance only. **VDA method This is the method used by the Verband der Automobilindustrie (VDA) in Germany. A VDA figure is determined by filling the loadspace with 'litre' blocks, each measuring 200x100x50 mm. The blocks are then counted, and the numerical result is converted into cubic metres.

***Charging performance for E-Transit Single Chassis Cab 425 GVM. Charge power can decrease with increasing state of charge. Actual charge times and charge speeds can vary based on different factors (e.g. weather, temperature, driving behaviour, route profile, vehicle condition, age and condition of the lithium-ion-battery, used charging infrastructure).

⁰The declared fuel/energy consumptions, CO₂-emissions and electric ranges are determined according to the technical requirements and specifications of the European Regulations (EC) 715/2007 and (EU) 2017/1151 as last amended. Light Duty vehicles type-approved using the Worldwide Harmonised Light Vehicle Test Procedure (WLTP) will have fuel/energy consumptions and CO₂-emission information for New European Drive Cycle (NEDC) and WLTP. WLTP will fully replace the NEDC latest by end of the year 2020. The applied standard test procedures enable comparison between different vehicle types and different manufacturers. In addition to the fuel efficiency of a vehicle, driving behaviour as well as other non-technical factors play a role in determining a vehicle's fuel/energy consumption, CO₂ emissions and electric ranges. CO₂ is the main greenhouse gas responsible for global warming.

⁰⁰Calculated via peak performance of the electric motor(s) at peak battery power. Your results may vary.

⁰⁰⁰Based on full charge of E-Transit Single Chassis Cab 425 GVM. Estimated range using Worldwide Harmonised Light Vehicle Test Procedure (WLTP). Figures shown are for comparability purposes and should only be compared with other vehicles tested to the same technical procedures. Actual range varies with conditions such as external elements like temperature, driving behaviours, route profile, vehicle maintenance, and lithium-ion battery age and condition. WLTP Overall Range reflects a combined driving cycle and WLTP Motorway Range reflects motorway driving – both tests are conducted in controlled conditions with an ambient temperature of 23 degrees Celsius and no climate or electrical load.

♦Kerb mass is affected by many factors such as bodystyles, engines and options. It is the weight of a standard-specification base vehicle (different series will have different kerb masses), including fluids and fuel tank 90% full, but without the driver (75 kg), crew or cargo. Payload within this guide is the difference between gross vehicle mass (GVM) and kerb mass with a further 75 kg deduction for the weight of the driver. It must be noted that actual weight will always be subject to manufacturing tolerances which may result in payload variations between this guide and actual weight. For customers intending to load vehicle close to maximum payload, we suggest you also add a margin for error of 5% of kerb mass to the kerb mass figure before calculation, to reduce risk of overloading.

NB: It is the responsibility of the vehicle operator to ensure their vehicles are legally compliant for road use. For rear float option vehicles, kerb mass is increased and payload reduced.

Note The charging rate decreases as battery reaches full capacity. Your results may vary based on peak charging times and battery state of charge.

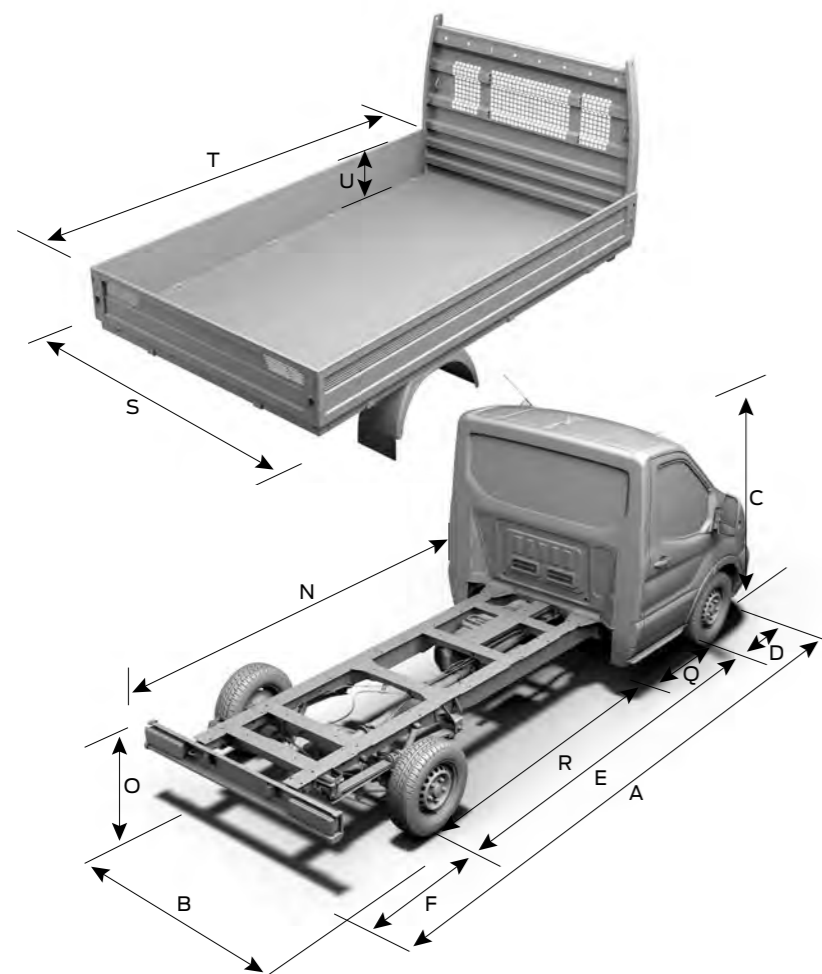

L3 H1



L4 H1