



TRANSIT DOUBLE CHASSIS CAB

Trend

- | | |
|---|---|
| <ul style="list-style-type: none"> ▪ Exterior Mirrors – Electric Powered and Heated ▪ Focused Quad Beam Headlights ▪ Daytime Running Lights ▪ Automatic headlights ▪ Front Fog Lamps ▪ Automatic Windshield Wiper ▪ Heated Windshield Defroster (Quickclear) ▪ Fixed Rear Window ▪ Driver airbag ▪ Driver's seat with 4 adjustments, lumbar support, and Armrest ▪ Dual Passenger Seat (with underneath storage) and Tray Table (Single passenger seat D/Cab 350EL with Passenger Airbag) ▪ 4 Rear Seats (for D/Cab) ▪ Automatic Air Condition ▪ Overhead Storage Compartment for Sunglasses ▪ Locking Lid Glove Box ▪ Header Mounted Courtesy with 2 Map Lights ▪ 8" Digital instrument cluster ▪ 12" touchscreen with SYNC 4, Bluetooth® for wireless phone connection, modem 5G FordPass Connect, AppLink, GNSS antenna (roof fin), 2 USB slots with connection capabilities, 4 speakers ▪ Wireless Apple CarPlay® and Android Auto™ connection ▪ Emergency Assistance | <ul style="list-style-type: none"> ▪ Cruise Control ▪ Front Parking Aid Sensors ▪ Digital Rear View Camera ▪ Speed Sign Recognition ▪ Pre-Collision Assist #2 – Collision Assistance with Emergency Brake Assist (Emergency Brake Assist), Active Braking, pedestrian detection with proximity warning (Forward Alert) ▪ Lane keeping aid (with warning Lane-Keeping Alert and Lane Keeping Aid assistance) ▪ Mechanical Parking Brake for N2 (500) double tire ▪ Electric Parking Brake for N1 (350) ▪ Electronic Stability Control (ESC) with traction control ▪ Hill Launch Assist ▪ Anti-lock Brake System (ABS) ▪ Roll Stability Control (RSC) ▪ Dual Rear Wheels (<i>Only for 500L5</i>) ▪ 16" Steel Wheels ▪ Conventional Steel Spare Wheel ▪ Stop/Start System ▪ Power Windows - Up/Down with one touch (drivers side only) ▪ Remote Central Locking ▪ Shielded Power Door Dead Locks ▪ Pick-up: Aluminium Drop Side Aluminium Float |
|---|---|

Transit Double Cab

Chassis

Pick-Up

350L3 (LWB) 2.0D EcoBlue 130PS RWD 6-Speed Manual	€ 40,000	€ 42,500
350L3 (LWB) 2.0D EcoBlue 165PS RWD 6-Speed Manual	€ 41,000	€ 43,500
350L4 (EF) 2.0D EcoBlue 130PS RWD 6-Speed Manual	€ 41,000	€ 44,000
350L4 (EF) 2.0D EcoBlue 165PS RWD 6-Speed Manual	€ 42,000	€ 45,000
350L5 (EL) 2.0D EcoBlue 165PS RWD 6-Speed Manual	€ 42,500	€ 45,400
500L5 (EL) 2.0D EcoBlue 165PS DRWD 10-Speed Automatic	€ 48,000	€ 51,000
Additional for AWD on 350L3 & 350L4 165PS Manual	€ 5,000	
Additional for Premium or Metallic Paint	€ 600	

5 Years Ford Protect Warranty* & 12 Years anti corrosion-warranty

* 5 year warranty or 200.000 kilometers (whichever comes first).

- The above prices include Import Taxes, VAT 19%, Registration and Road Tax.
- Prices and equipment may change without prior notification.

Double Cab Dimensions (mm)

	L3 Chassis – Double Cab	L4 Chassis – Double Cab	L5 Chassis – Double Cab
	RWD/ AWD	RWD	RWD
A Overall length	6022	6579	7577
B Overall width with mirrors (standard/wide)	2474/2746	2474/2746	2474/2746
Overall width with folded back mirrors (standard/wide)	2112/2119	2112/2119	2112/2119
Overall width without mirrors (DRW)	2111	2111	2111
C Overall height (maximum)	2218	2220	2211
D Front of vehicle to front wheel centre	1023	1023	1023
E Wheelbase	3954	3954	4522
F Rear of vehicle to rear wheel centre	1045	1427	1849
N Chassis frame length	2777	3159	4149
O Floor/chassis frame height*	715/735	717/734	722/742
Q Rear of cab to front wheel centre	2222	2222	2222
R Rear of cab to rear wheel centre	1732	1732	2300
Float dimensions (mm)**			
Overall length (including float)	6204	6587	7612
Overall width (including float) without mirrors (DRW)	2198	2198	2198
Internal loadspace width (DRW)	2138	2138	2138
Internal loadspace length	2795	3205	4235
Turning circle (m)			
Kerb to kerb	14.0	14.0	15.8

L3 = Long wheelbase, **RWD** = Rear-wheel drive, **AWD** = All-wheel drive, **DRW** = Dual rear wheel. All dimension (shown in mm) are subject to manufacturing tolerance +/- 50mm and refer to minimum models. All bodywork and equipment must be fitted in accordance with the Transit Body and Equipment Mounting Manual

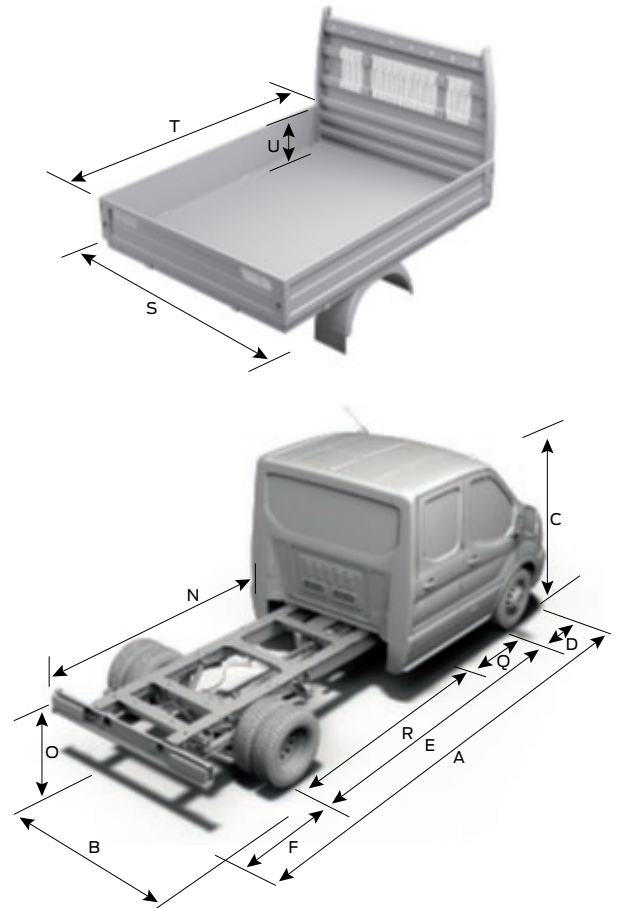

Weights and loads

	Max. gross payload (excluding driver) (kg)	Gross vehicle mass (kg)	Min. kerb mass [♦] (excluding driver) (kg)	Front axle plated mass (kg)	Rear axle plated mass (kg)
Double Cab Chassis (7 Seats)					
RWD					
350 L3	1390-1443	3550	2107-2160	1750/1850	2250/2450
350 L4	1373-1426	3550	2124-2177	1750/1850	2250/2450
350 L5	1317-1371	3550	2179-2233	1850	2250/2450
500 L5	2428-2508	5000	2352-2432	1850	3300
Double Cab Pick-Up (7 Seats)					
RWD					
350 L3	1112-1165	3550	2385-2438	1750/1850	2250/2450
350 L4	1067-1120	3550	2430-2483	1750/1850	2250/2450
350 L5	940-994	3550	2556-2610	1850	2250/2450
500 L5	2051-2131	5000	2658-2780	1850	3300

